



*International J/70 Class Association*

# J/70 EQUIPMENT REGULATIONS (J70ER)

[ Version: 2024-01 | Current version is always published at <https://j70ica.org/class-office-rules/> ]

Feedback on this document is appreciated.

Contact the IJ70CA Technical Committee Chair or the J/70 Class Office with questions, comments, or suggestions.

---

Text in **bold** refers to the definition in the Equipment Rules of Sailing (ERS).

Text in *italics* refers to the definition in the Racing Rules of Sailing (RRS).

## 1. STATUS OF THESE REGULATIONS

- 1.1 These J/70 Equipment Regulations (J70ER) are intended to be binding on all boats except as otherwise indicated herein.
- 1.2 These J70ER may be amended by approval of the International J/70 Class Association (IJ70CA) Executive Committee. The current version at the beginning of an event's inspection period is the binding version for that event.
- 1.3 Provisions of these J70ER may be altered for an event only by approval of the IJ70CA Executive Committee; any such changes should be specified in the Notice of Race (NoR) and/or the Sailing Instructions (SIs).
- 1.4 For purposes of RRS 92, the "technical committee" will be the event Technical Committee appointed by the event Organizing Authority (OA) and approved by the IJ70CA.

## 2. EVENT EQUIPMENT RULES

- 2.1 All **boats**, **sails**, **portable equipment**, and mandatory **personal equipment** must be in compliance with the following:
  - (a) The current International J/70 Class Rules (J70CR) (published at <https://j70ica.org/class-office-rules/>);
  - (b) The current World Sailing Equipment Rules of Sailing (ERS) (published at <https://www.sailing.org/inside-world-sailing/rules-regulations/equipment-rules-of-sailing/>);
  - (c) The current J/70 Building Specification (published at <https://j70ica.org/class-office-rules/>);
  - (d) These J/70 Equipment Regulations (J70ER) (published at <https://j70ica.org/class-office-rules/>).

### 3. PERSON IN CHARGE

- 3.1 Each owner/charterer shall designate one person in charge pursuant to RRS 46. The person in charge is responsible for providing all relevant documents and other information, completing any required inspection forms, making inspection appointments, representing the boat during the inspection process, and responding to requests by the event Technical Committee.

### 4. COMPLIANCE

- 4.1 RRS 78.1 is in effect from the completion of a boat's inspection until the end of the event. At all times after the completion of a boat's inspection, the owner and/or person in charge shall ensure that the **boat, sails, portable equipment**, and mandatory **personal equipment** are maintained to comply with the Event Equipment Rules of J70ER 2, and that the boat's IJ70CA Manufacturer's Declaration (J70MD) remains valid.
- 4.2 **Boats, sails, portable equipment**, and mandatory **personal equipment** are subject to inspection for compliance with the Event Equipment Rules of J70ER 2 during the times specified in J70ER 4.1. Inspections may occur with or without prior notice.
- 4.3 The boat's **sails, portable equipment**, (less electronics/radios that need to be recharged) and mandatory **personal equipment** used and/or carried aboard while *racing*, as well as the **rig**, and **appendages** shall not be removed from boats after inspection until the end of the event, except pursuant to J70ER 10. Keels and rudders shall not be lifted or removed from the water except pursuant to J70ER 10.

### 5. REQUIREMENTS PRIOR TO EVENT CHECK IN

- 5.1 Prior to final check in at the event, the person in charge shall arrange for the following:
- (a) Provide the OA and/or the event Technical Committee with a valid and current copy of the boat's IJ70CA Manufacturer's Declaration (J70MD). See J70CR A.10, J70CR A.11 and J70CR C.5.2(10). Boats arriving to the event without a valid J70MD must make advance arrangements with the OA to obtain one; a fee will apply for this service. This changes RRS 78.2.
  - (b) Present for inspection **sails** that have been certified by an **official measurer** or by a manufacturer licensed under World Sailing In-House Certification. See J70CR G.2. Sails presented without certification may be certified on site by advance arrangement with the OA; a fee will apply for this service.
  - (c) If required in the NoR and/or SI, ensure that any bow numbers and any other OA-provided markings are affixed to the boat (see J70ER 6).
  - (d) If required in the NoR and/or SI, submit a J/70 Class Rules Compliance Declaration Form (see J70ER 7).
  - (e) If required in the NOR and/or SI, make arrangements for the **boat** to be inspected (see J70ER 8).
  - (f) If required in the NoR and/or SI, make arrangements for the **sails** to be inspected (see J70ER 9);

### 6. BOW NUMBERS & OTHER OA-PROVIDED MARKINGS

- 6.1 If specified in the NoR and/or SIs, event bow numbers shall be provided by the OA and will be as described in Appendix A.
- 6.2 Bow numbers shall be affixed so that the leading edge of the number is no more than 216mm from the of the bow and the top edge of the number(s) is within 127mm of the **sheerline**. See J70ER Appendix A for diagrams.
- 6.3 **Event limitation marks**, stickers, or stamps may be applied to the **boat, sails**, or other equipment during the inspection process by the inspection team.

- 6.4 Boats may be required to display advertising chosen and supplied by the OA from the close of check-in through the end of the event.
- 6.5 Any accidental removal of the items described in this J70ER 6 shall be promptly reported to the event Technical Committee, or in its absence the Race Committee.

## 7. J/70 CLASS RULES COMPLIANCE DECLARATION FORM

- 7.1 If specified in the NoR and/or SIs, the person in charge shall complete and submit a signed J/70 Class Rules Compliance Declaration Form prior to check in for the event.
- 7.2 The IJ70CA, in collaboration with the OA and/or the event Technical Committee will determine the format and content of the Compliance Declaration Form. The OA will notify competitors whether the Compliance Declaration Form may be completed online or in hard copy and will distribute the form (or a link to the form) shortly before the event. Competitors having trouble accessing the Compliance Declaration Form should contact the OA or a member of the event Technical Committee for assistance.
- 7.3 **Equipment inspectors** will be available during the inspection period designated in the NoR to answer questions about the Compliance Declaration Form or the required items.
- 7.4 Competitors are reminded that provisions of the Event Equipment Rules in J70ER 2 not listed on the Compliance Declaration Form may also be the basis for inspection and/or protest in the event of non-compliance. Pursuant to J70ER 4, boats are subject to inspection at any time throughout the event.

## 8. BOAT INSPECTION

- 8.1 If required in the NOR and/or SI, the person in charge shall arrange for an inspection time for the boat using scheduling tools provided by the OA.
- 8.2 The NOR and/or the SI may specify that boat inspection must occur with the boat out of the water.
- 8.3 At least two crew from each boat shall attend the inspection appointment.
- 8.4 All equipment and **corrector weights** shall be made accessible to inspectors.
- 8.5 Boat inspection may include but is not limited to: checking conformance with the current J70MD; inspecting standing and/or running rigging and associated fittings; testing lifeline tension; checking deck layout, required equipment, personal flotation devices, hull shape compliance, and keel and rudder shape compliance; and boat weighing.
- 8.6 Boat weighing:
  - (a) The NOR and/or SI may specify that all boats must be weighed.
  - (b) Any boat may be requested to be weighed by an Equipment Inspector, the event Technical Committee, or the OA at any time during the event.
  - (c) Boats will be weighed dry according to the provisions of J70CR C.6.1.
  - (d) In general, only one weighing attempt shall be permitted; no optimization attempts are allowed.
  - (e) In cases where **corrector weights** need to be installed: the **corrector weights** will be weighed separately on a suitable scale; and the installation of the **corrector weights** shall be according to J70CR Appendix H-2 and confirmed by the **Official Measurer** or **Equipment Inspector** in charge.
- 8.7 If required in the NOR and/or SI, prior to checking in, each boat must either submit or have submitted on its behalf a signed and completed boat inspection checklist according to procedures established by the OA or the Event Technical Committee.

## 9. SAILS INSPECTION

- 9.1 If required in the NOR and/or SI, the person in charge shall arrange for an inspection time for the **sails** using the scheduling tools provided by the OA.
- 9.2 **Sails** to be carried while racing shall arrive at the sail inspection area 5 minutes before each scheduled appointment, with at least two crew members to assist the inspections.
- 9.3 **Sails** shall be presented for inspection in dry condition with leech, luff and foot cords untied and with all battens removed.
- 9.4 After inspection, **sails** shall be immediately returned to the boat and kept on the boat until the end of the event pursuant to J70ER 4.
- 9.5 If required in the NOR and/or SI, prior to checking in each boat must either submit or have submitted on its behalf a signed and completed sail inspection checklist according to procedures established by the OA or the event Technical Committee.

## 10. REPAIR, REPLACEMENT AND ALTERATION OF EQUIPMENT

- 10.1 Any repair, replacement or alteration of the **boat, sails, portable equipment**, and mandatory **personal equipment** after inspection and until the end of the event shall require the prior approval of the event Technical Committee or in its absence the Race Committee before *racing* and may be subject to inspection before further *racing*.
- 10.2 Repairs, replacement, or alterations required on the water may be approved each day after *racing* provided the event Technical Committee or in its absence the Race Committee is notified before *racing*.
- 10.3 The procedures (including any forms) for requesting the approval required under this J70ER 10 may be determined by the OA and/or the event Technical Committee.

## 11. PROTESTS & PENALTIES

- 11.1 The event Technical Committee may protest a boat for violations of these J70ER. This adds to RRS 60.4.
- 11.2 Violations of the J70ER and/or the Event Equipment Rules (J70ER 2) prior to the start of *racing* may be reported and protested by the event Technical Committee after the end of the check in time specified in the NOR and/or SI as if it were discovered after *racing* on the first day on which races are completed.
- 11.3 The protest committee or international jury may impose suitable penalties, other than disqualification, for violations of these J/70 Equipment Regulations or the Event Equipment Rules listed in J70ER 2. However, in no case shall the penalty for such a violation be less than a ten percent (10%) scoring penalty calculated pursuant to RRS 44.3(c). This changes RRS 64.6.

# J70ER APPENDIX A

## BOW NUMBER POSITIONING

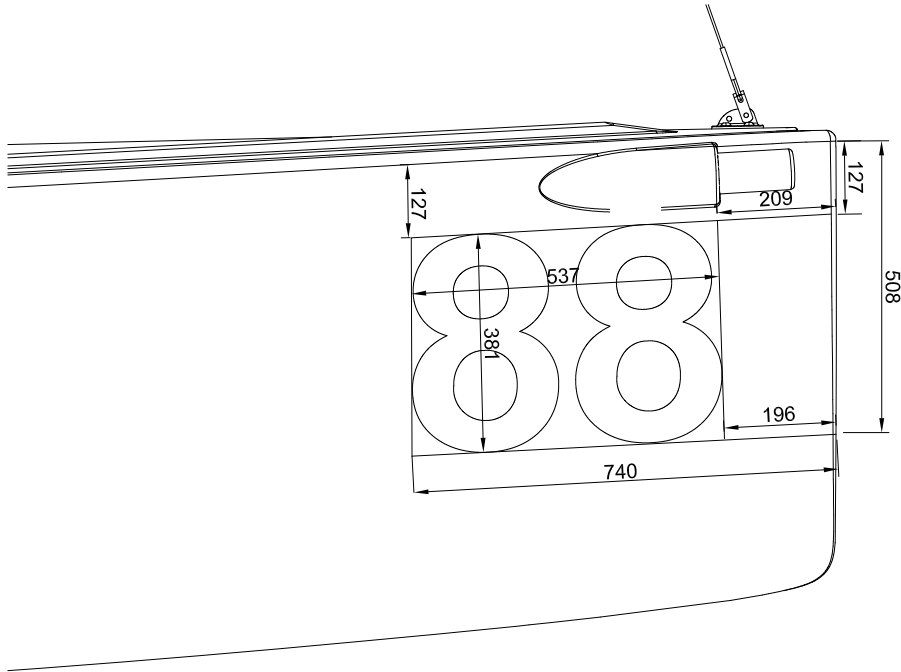

Layout for  
381mm / 15 inch  
numbers.

J/70 Class Bow Number Location & Size #1

Standard number - height = 381mm (15")  
Dimensions in mm  
6-11-2018

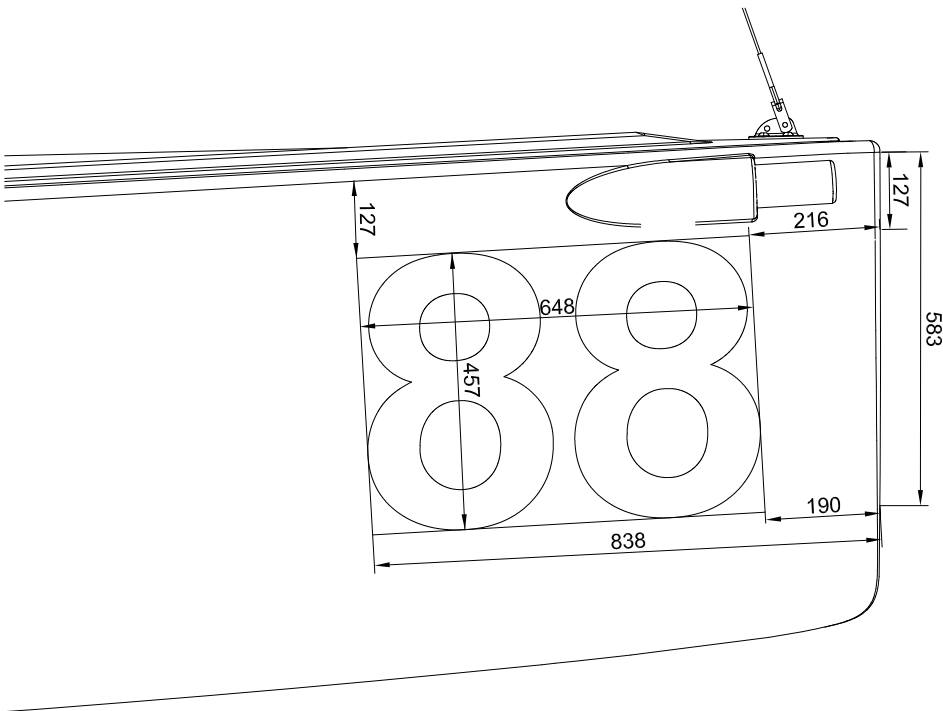

Layout for  
457mm / 18 inch  
numbers.

J/70 Class Bow Number Location & Size #2

Large number - height = 457mm (18")  
Dimensions in mm  
6-11-2018